

LBK System

3D SAFETY RADAR

WORLD FIRST
SIL2
Pld
RADAR SYSTEM

3D SAFETY RADAR

LBK System

The first certified volumetric radar safety system. Thanks to its unique features, it transforms the state of the art of industrial automation, increasing safety without compromising productivity.



LBK-S01

LBK-C22

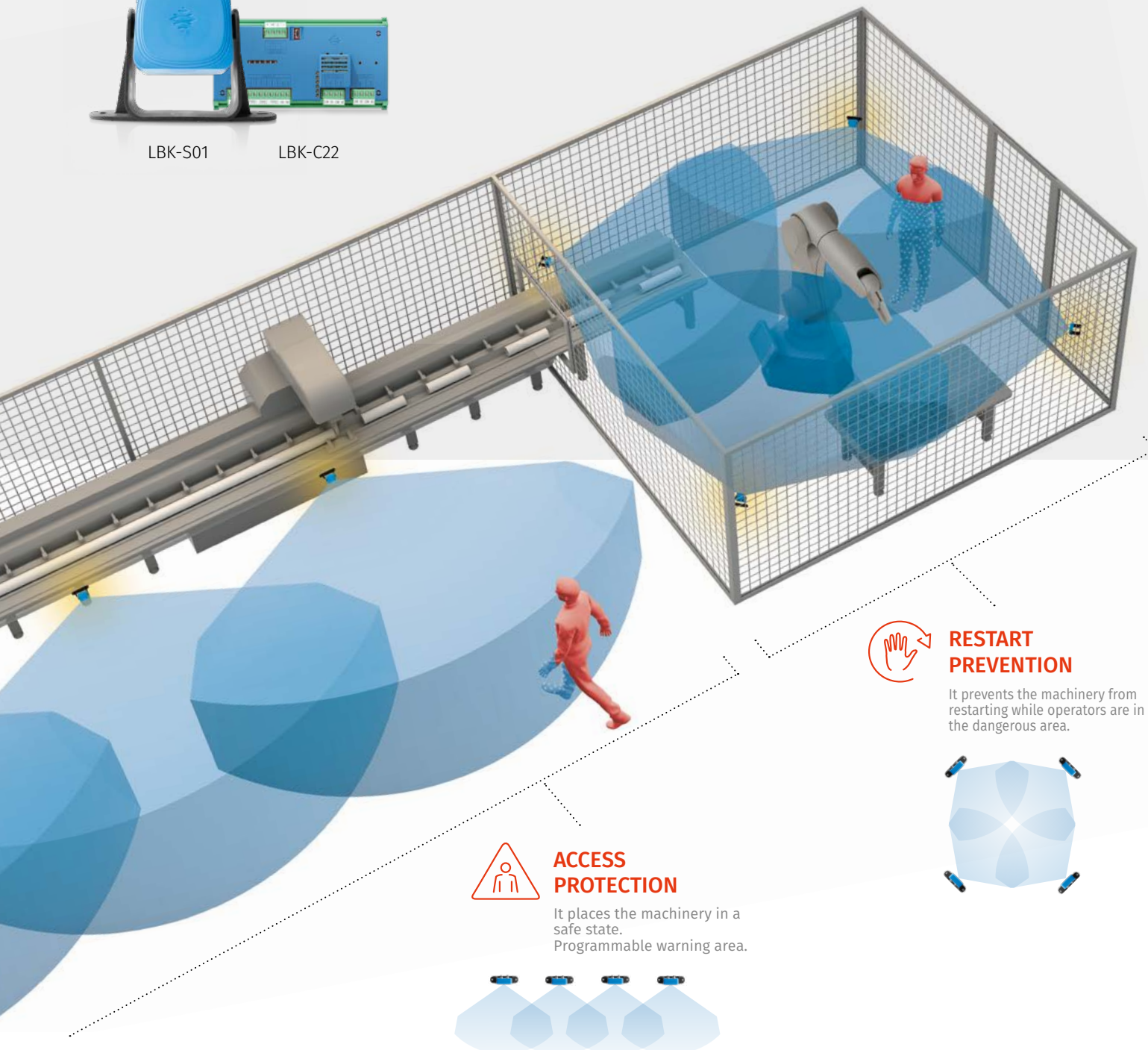

RESTART PREVENTION

It prevents the machinery from restarting while operators are in the dangerous area.

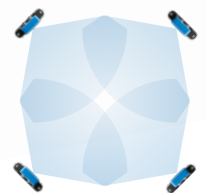

ACCESS PROTECTION

It places the machinery in a safe state.
Programmable warning area.

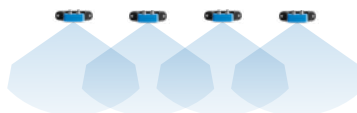

World's first SIL2/Pld radar system.

For the protection of operators in industrial safety applications.



Safe RESTART function.

The LBK System can detect the presence of operators in the dangerous area, preventing accidental restarts of the machinery.



It works where optical sensors stop.

The LBK System is immune to environmental disturbances such as smoke, dust, shavings, splashes or machining waste.



High safety without compromising productivity



Optical devices often fail due to dust, smoke, water or waste generated by the production process. The Inxpect team, highly specialized in radar technology, has developed a sophisticated 24 GHz radar algorithm that filters out those disturbances, reducing false alarms and increasing productivity.

Easy setup

INXPECT SAFETY APPLICATION

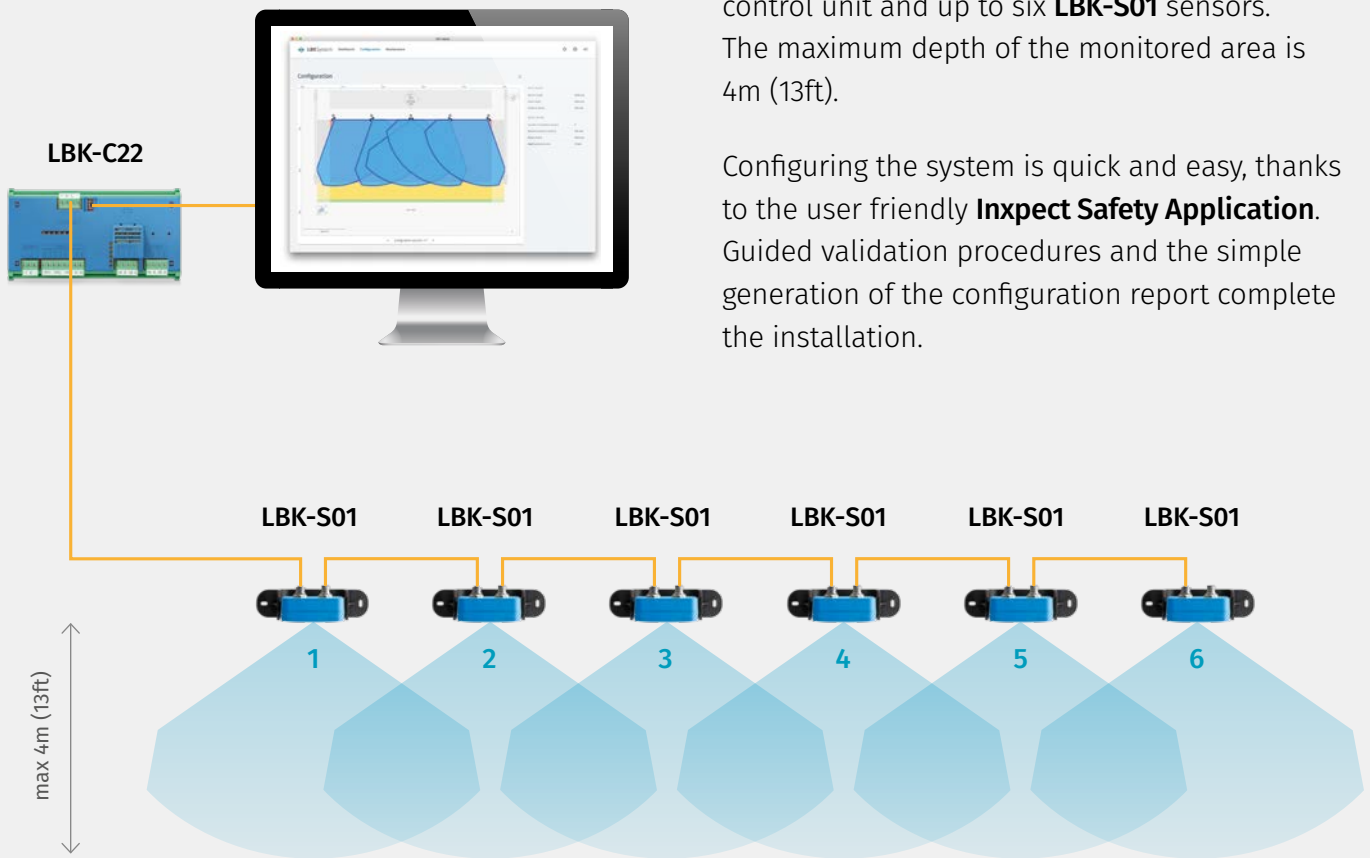

The LBK System is composed of the **LBK-C22** control unit and up to six **LBK-S01** sensors. The maximum depth of the monitored area is 4m (13ft).

Configuring the system is quick and easy, thanks to the user friendly **Inxpect Safety Application**. Guided validation procedures and the simple generation of the configuration report complete the installation.

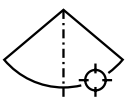

A perfect alignment between sensors is not required.



The provided Inxpect Safety Application allows multiple configuration modes: automatic for regular-shaped areas, manual for the monitoring of more complex areas.

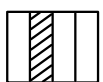

Programmable Muting function: the configuration of sensor groups that can be temporarily muted allows operators to safely access parts of the dangerous area, according to production needs.

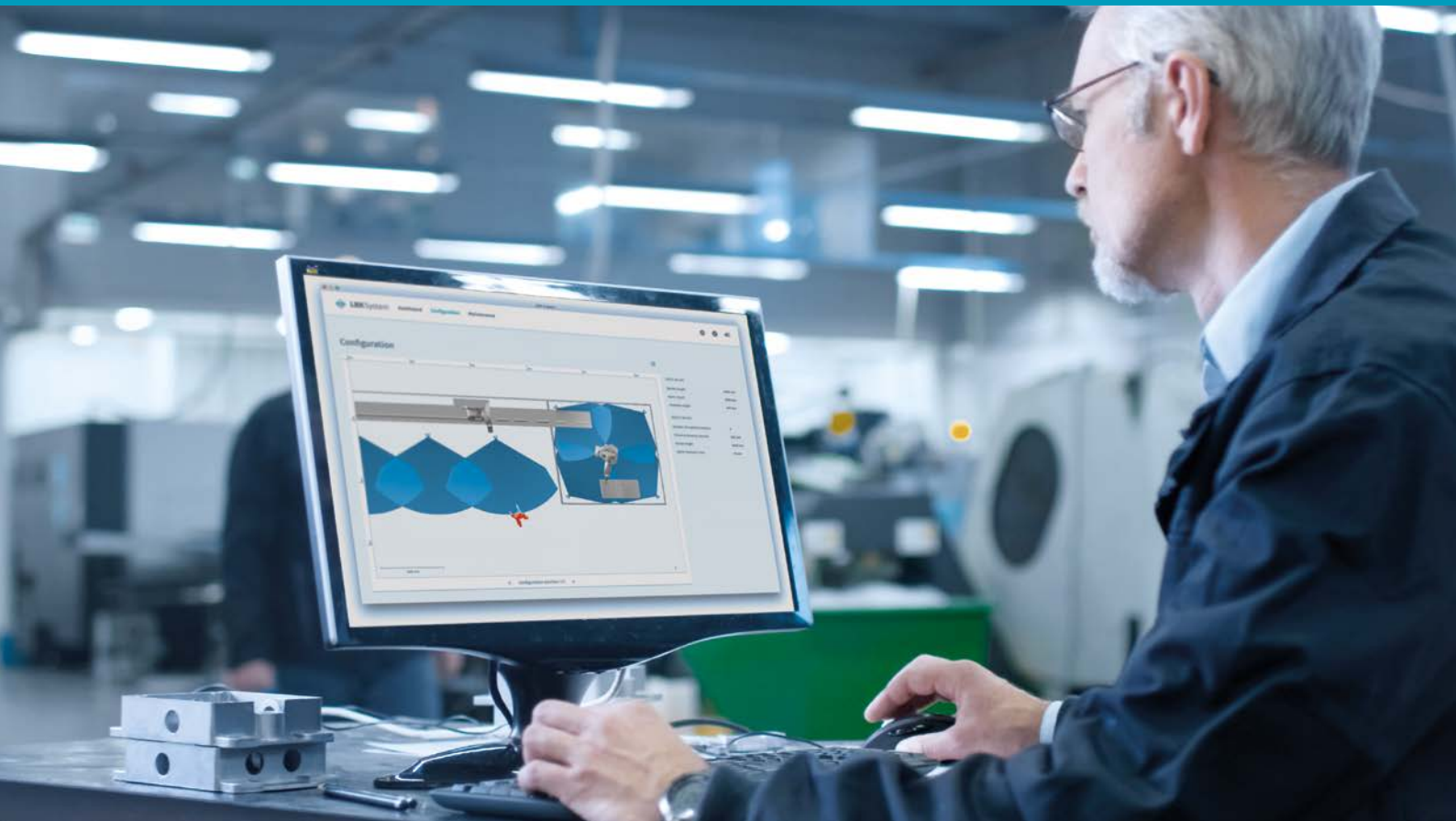

Sensing field

Each LBK-S01 sensor in the LBK System can be field-programmed, independently from the others, to cover either a Wide or a Narrow sensing field. The actual covered area of each sensor depends on installation height and tilt.

WIDE COVERAGE FIELD

Horizontal Plane: 110°

Vertical Plane: 30°

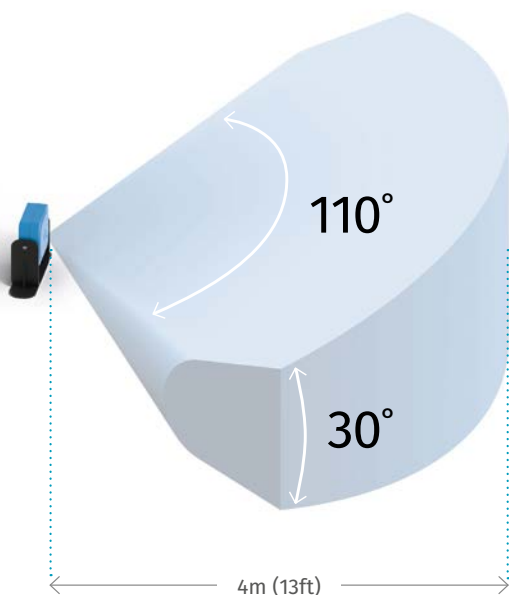

NARROW COVERAGE FIELD

Horizontal Plane: 50°

Vertical Plane: 15°

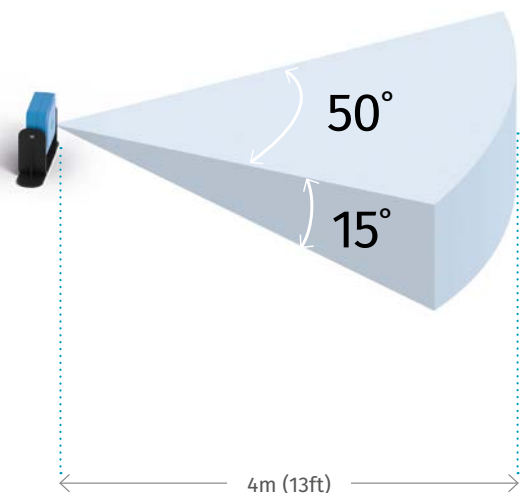



LBK-S01

The smart radar sensor



The **LBK-S01** sensor is a smart FMCW (Frequency Modulated Continuous Wave) radar device based on proprietary Inxpect detection algorithms.

The sensor sends 24 GHz radio waves and recovers motion information, analyzing the returned signals reflected by both static and moving objects in the operative range.

The sensors perform the following primary functions:

- **Motion and scenario analysis.**
- **Communication via CAN bus to the controller of the motion detection signal.**
- **Fault reporting and communication of diagnostic information via CAN bus to the controller.**



WORLD FIRST
SIL2
Pld
 RADAR SYSTEM



The plastic cover is an optional accessory.



Auxiliary outputs

The controller has two auxiliary relay outputs, which can be configured to signal: pre-alarm, fault, muting status.

LBK-C22

The control unit

The Inxpect **LBK-C22** is the system control unit. It can connect up to six LBK-S01 smart sensors. Intervention of any single sensor results in the deactivation of the controller's safety output.

The LBK-C22 control unit can be configured with the Inxpect Safety PC application through USB cable connection, which allows the configuration of sensitivity levels, safety functions, size of warning and dangerous areas, and the functionality of the controller's I/O ports.

Digital inputs

The controller has three dual-channel digital inputs and common reference potential for:

- muting
(high logic level (1) = muting enabled)
- machinery emergency button
(low logic level (0) = stopping enabled)
- machinery restart button enabled
(high logic level (1) = restart enabled)

The digital inputs can be configured through the Inxpect Safety application software.

Safety outputs

The controller has one dual-channel, force-guided safety relay output for alarms and direct or indirect safety of the machinery.

Dimensions



Conformity



Directives 2006/42/EC (MD - Machinery)
2014/53/EU (RED - Radio equipment)

Standards IEC/EN 62061: 2005 SIL 2
EN ISO 13849-1: 2015 PL d
EN ISO 13849-2: 2012
IEC/EN 61496-1: 2013
IEC/EN 61508: 2010 Part 1-7 SIL 2
ETSI EN 300 440 v2.1.1
ETSI EN 301 489-1 v2.2.0 (only emissions)
ETSI EN 301 489-3 v2.1.1 (only emissions)
IEC/EN 61326-3-1: 2017
IEC/EN 61010-1: 2010

General

| | |
|--|---|
| Detection method | Inspect motion detection algorithm based on FMCW radar |
| Frequency | Working band: 24–24,25 GHz (24.05-24.25 for UK and FR) Transmission power: ≤ 13 dBm - Modulation: FMCW |
| Detection interval | From 0 to 4 m (0 to 13.1 ft), depending on the installation conditions |
| Sensing field and Installation height | Wide FOV configuration: 110° Horiz. 30° Vert., Height: 0 to 3 m (0 to 9.8 ft) Narrow FOV configuration: 50° Horiz. 15° Vert., Height: 0 to 3 m (0 to 9.8 ft) |
| Guaranteed response time | < 100 ms |
| SIL (Safety Integrity Level) | 2 |
| PL (Performance Level) | d |
| Category | 2 (3 for the outputs) |
| Total consumption | 11 W (controller and six sensors) |
| Operating Temperature | From -40 to +60 °C (-40 to +140 °F) |
| Storage Temperature | From -40 to +80 °C (-40 to +176 °F) |
| Communication protocol (sensors-controller) | CAN complies with standard EN 50325-5 |
| Warranty period | 36 months from the date of purchase of the product |

Sensor

| | |
|---------------------------------------|--|
| Connectors | 2 5-pin M12 connectors (1 male and 1 female) |
| CAN bus termination resistance | 120 Ω (not supplied, to be installed with termination connector) |
| Power supply | 12 V dc ± 20%, through controller |
| Degree of protection | IP67 |
| Material | Sensor case: PA66 Bracket: PA66 and glass fiber (GF) |

Controller

| | |
|--------------------------------|---|
| Outputs | 4 relay outputs: 1 dual channel safety output 2 auxiliary outputs |
| Safety relay outputs | Forced guided relays Max voltage: 30 V dc Max current: 8 A dc Max power: 240W |
| Auxiliary relay outputs | Electromechanical relays Max voltage: 30 V dc Max current: 2 A dc Max power: 60W |
| Inputs | 3 dual channel digital inputs with common GND: 1 type 1 1 type 2 1 type 3 |
| Power supply | 24 V dc (20–28 V dc) Max current: 0.6A |
| Consumption | Max 3.8W |
| Assembly | DIN guide |
| Degree of protection | IP20 |
| Terminals | Section: 2.5mm ² Max Current: 12A with 2.5mm ² cables |

CAN bus cables

| | |
|-------------------|---|
| Section | 2 x 0.34mm ² power supply - 2 x 0.34mm ² data |
| Type | Two twisted pairs: power supply and data |
| Connectors | 5-pole M12 |
| Impedance | 120 Ω ±12 Ω (f = 1 MHz) |
| Shield | Shield with twisted wires in tin-plated copper. Requires ground connection. |
| Length | 30m (98.4ft) from controller to sensor (configuration with 1 sensor) |